

Climats

# EXCAL 3

Expert in environmental simulation

CREATOR  
OF EXTREME

CLIMATIC CHAMBER

- ▶ POWERFUL
- ▶ ERGONOMIC
- ▶ SPIRALE VISION

50°C  
CO<sub>2</sub>



# EXCAL<sup>3</sup>



▶ Aeronautics and space



▶ Automotive



▶ Defense



▶ Electronics



▶ Renewable energies



▶ Test laboratories

Climats has been a specialist in environmental tests since 1974, designs and manufactures chambers that can simulate extreme and reproducible environments. Present in sectors as diverse as automotive, aeronautics, space, defense and telecommunications, Climats helps guarantee the best level of performance, reliability and safety for your products. Our "Research and Development" department, focusing entirely on quality and innovation, works towards improving the efficiency, adaptability and ergonomics of the EXCAL<sup>3</sup> range. Our environmental test chambers are continuously changing to meet the latest testing standards.

Cold	Dry heat	Temperature variation	Humid heat	Climatic cycles	Ice
NF EN 60068-2-1 NF EN 60068-2-50 GAM EG 13 fasc 01 MIL STD 810/502-2	NF EN 60068-2-2 NF EN 60068-2-51 GAM EG 13 fasc 02 MIL STD 810/502-2	NF EN 60068-2-14 GAM EG 13 RTCA DO160 SEC5	NF EN 60068-2-30 NF EN 60068-2-38 NF EN 60068-2-78 GAM EG 13 fasc 03 MIL STD 810/507 RTCA DO160 SEC6 NF C 20-703	GAM EG13 fasc 08	

Examples of managed test standards

## An entirely French design

Every year, over 300 environmental test chambers are designed, manufactured and assembled in our Bordeaux production unit. Today, we are pleased and proud to introduce a completely new generation of EXCAL<sup>3</sup> environmental test chambers, which is the result of Climats's experience and expertise.

“Our ambition ?  
To offer powerful, intuitive  
solutions designed for a  
more environmentally-  
friendly future.”

**Technology EXCAL<sup>3</sup> for  
future generations !**



### A customized environmental test chamber

Your applications require specific functions and capacities, which is why Climats has a wide range of comprehensive standard machines. Our volumes have been designed and engineered so that you can add any of the options enabling you to customize your EXCAL<sup>3</sup> to your needs.

### High end technology

Spirale Vision is the reference software solution for controlling over 5,000 environmental test chambers and test benches worldwide. It was developed by Climats's engineers for simple and efficient management of your machine.

Spirale Vision is a reliable and accurate system, a complete software package, adapted to testing equipment and maintenance user requirements.

Spirale Vision is also a completely open system that can be used for developing automatic functions and integrating data and additional data acquisition systems, to make your EXCAL<sup>3</sup> a fully integrated test bench.

### Energy saving

10 years of continuous research and development have culminated in the development of a revolutionary feature for protecting the environment.

Unique on the market, the **ENERGY SAVING** control mode, in Spirale Vision, scrupulously controls your energy consumption. A saving of at least 40% can be made on the electrical consumption of your typical cycles. You can monitor the instant electrical consumption of the chamber during the test or check the total consumption for the whole test.

Reduced water consumption for the cooling system also constitutes a new environmental breakthrough.



**R744 fluid: GWP of 1,  
low environmental impact**

R744(CO<sub>2</sub>), a natural, sustainable refrigerant, is now used for efficient testing down to -50°C.

Thanks to an innovative design, our refrigeration unit minimizes gas charge, eliminating the requirement for mandatory annual leak checks. Reduce your carbon footprint while ensuring reliable testing with a sustainable, environmentally-friendly solution.

For applications below -50°C, EXCAL<sup>3</sup> is available in a cascade version.



This standard test cycle clearly shows the energy saved with the “**Energy saving**” cycle (dark grey curve) compared with a cycle without this mode (light grey curve). Electrical consumptions are displayed instantly.

### Even more reliable

This regulation system has been developed, incorporating feedback from our customers and our research on ecological advances. So, the Energy Saving mode helps to significantly reduce the load on the various components involved in refrigeration (solenoid valves, compressors and fans). Spirale Vision autonomously and optimally manages the production of cold and heat.

# EXCAL<sup>3</sup> INNOVATION

Enhance your test laboratory thanks to the modern design, and pure and elegant lines of the new EXCAL<sup>3</sup>.

### The most advanced technology

EXCAL<sup>3</sup> is equipped with a 15-inch capacitive multitouch Panel PC, an SSD memory, Windows 10 and 2 USB ports. It therefore includes all of the latest technological advances.

Even greater connectivity: you have the possibility of networking your equipment, developing automatic functions, and having a completely upgradeable machine.

Your connections are now completely centralized on the User Interface Panel (UIP).

### Choose your cooling mode

Your chamber can be equipped with a water or air-cooled condenser.

Improved sound insulation and more stable performances, regardless of the ambient temperature of your test room.

Installing an EXCAL<sup>3</sup> environmental test chamber equipped with an air-cooled condenser in your workspace couldn't be easier, all you need is an electrical connection.





## Ergonomy

8 standard solutions:

151 l, 227 l, 400 l, 540 l, 770 l, 1000 l, 1400 l, 1800 l.

A vast range: choose the footprint suitable for your workspace. The 151L and 227L volumes adapt to smallest test laboratories thanks to their new dimensions, allowing access through a standard door.

For ideal positioning of your products in the chamber, shelves (dismantled) are arranged throughout the entire height of the test volume.

You can optimize your tests using several shelves for the same test.

Totally adaptable test spaces. Depending on your requirements, we can integrate fastener inserts, specific mechanical and electrical fittings or make specific penetrations (air extractor, gas injection, sampling).

The new design door can be opened fully and provides easy access for introducing your test products into the chamber. The door can be closed with one hand thanks to the solid and robust handle.



Keep in touch with your tested products using the  $\varnothing$  100 mm portholes on each side, as standard and portholes  $\varnothing$  18mm on one side. Depending on the connectors and positions indicated in the specification, optional diameter ( $\varnothing$  80 mm,  $\varnothing$  150 mm,  $\varnothing$  200 mm) or any other shape portholes are available.

During testing, a large anti-condensation window offers maximum visibility of the materials being tested.

The materials constituting the test space (304L stainless steel) are resistant and scratch-proof. Treatment against chemical hazards (316L stainless steel) is offered as an option. The condensates flow directly on to the inclined base for rapid cleaning.

## Performances

- ▶ Homogeneity:  $\pm 0.4$  °C to  $\pm 1.5$  °C
- ▶ Temperature regulation stability:  $\pm 0.1$  °C to  $\pm 0.3$  °C
- ▶ Humidity regulation stability:  $\pm 2$  %
- ▶ Temperature range:  $-50$  °C  $+180$  °C /  $-90$  °C  $+180$  °C  
Optional: Extension  $+200$  °C,  $+250$  °C
- ▶ Transition speed: From 2 °C to 25 °C/min
- ▶ Humidity range: Stable and reproducible between 5% and 98%  
Optional: Direct measurement/Saturation/Dry rate
- ▶ Heat compensation: From 1000 W to over 10 kW



## Operating status

Visualize your operating status of your climatic chamber at a glance:

- ▶ green, cycle in progress
- ▶ white, power on
- ▶ red, malfunction (alarm or fault)

# EXCAL<sup>3</sup> USEFUL TECHNOLOGY



## Ergonomic control panel

The new hardware system includes the latest industrial innovations with the 15-inch capacitive multitouch Panel PC, passive under Windows 10. This solid and robust Panel PC is conveniently positioned so you can incline it as required. Connect your USB stick directly to the 2 USB port available or use the network connection to archive your tests.



## User Interface Panel (UIP): centralised connections

Ever attentive to user comfort and driven by our desire to continuously improve our products, we have created a space entirely dedicated to your connections. A panel positioned on the side of the chamber is provided for this purpose. You have a safety socket (as option), status indicators and 8 dry contacts that can be configured in Spirale Vision. Other innovation: 6 logical outputs (including 4 dry contacts); 8 inputs logical ; 6 analogical inputs/outputs that can be configured in Spirale Vision ; 2 TI inputs ; Run and defaults contacts and an Ethernet connection to control your chamber remotely.

# "Efficiency, safety, control... a step further with Spirale Vision"

## Control system integrating the reference M.M.I. (Man-Machine Interface)

Your control panel and all the components (test manager, program editor, etc.) benefit from remarkable ergonomics: a new user interface, instantaneous multilingual switch, ease of use, attention to detail and optimized design for use of the touch screen.



## Control panel with 3 user levels

You choose the most suitable interface: production, laboratory, advanced tests.

## Numerous configuration options

Access to these options and to the equipment commands can be controlled by nine password levels.

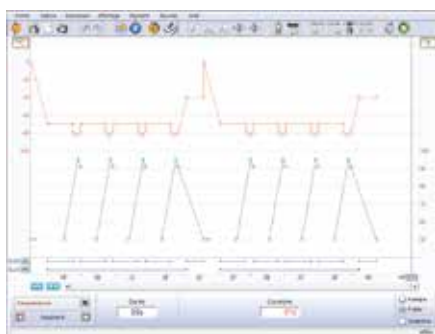

Our program editor, in this version of Spirale Vision, allows advanced programming operations (loops, on/off, "wait-for"), while being very easy to access with the possibility to «draw» your profiles on the screen.

Spirale Vision includes a user-friendly and complete test manager for accurate and easy traceability. Editing statistics, exporting data and analyzing information (rates, stability) is quick and easy.

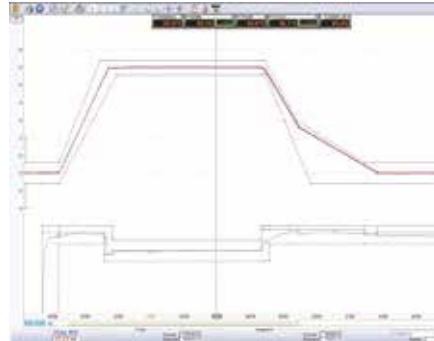

## User Script

This tool combines power and simplicity with its integrated help tool. You can create your own developments or submit them to us: automatic functions or specific safety functions, transform your EXCAL<sup>3</sup> into a fully integrated test bench.

## Network/Internet

A Spirale Vision exclusive feature, EXCAL<sup>3</sup> remote control is as easy as creating a shortcut on Windows desktop and you don't need to install any software on your desktop PC. A built-in web server checks your equipment's status using any Internet browser.

If the equipment alarm is activated or at the end of a test, Spirale automatically tells you by sending a message.

## Supervision

This solution quite simply lets you manage all your equipment, new and old, from a single workstation. Monitoring tools, profile creation, test report printing and email or SMS alarm setting functions are therefore available for all your testing equipment.

## Badge reader (as standard)

The EXCAL<sup>3</sup> is equipped with a badge reader as standard. You can identify yourself via your company badge, telephone or any other device using NFC technology. Cyber security is at the heart of this system. Each operator has his or her own access. There's no room for error, and user traceability is flawless.

## Tracking alarm

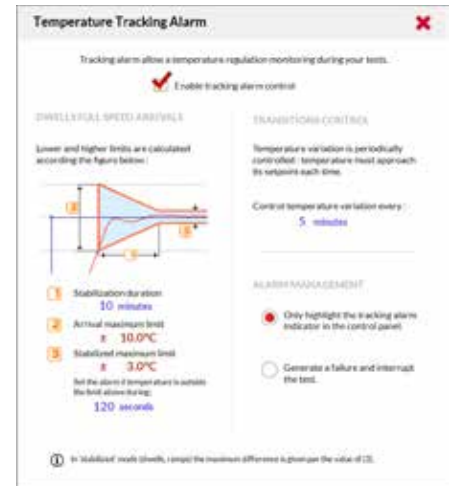

## Camera

You now have the possibility to periodically photograph your products during the tests thanks to the camera option, and to group them in photo galleries. The interval for taking photos is configurable.

## Usage statistics

This solution gives you the possibility to track equipment usage rate and energy consumption.

Month	2021-04	2021-03	2021-02
Tests Number	1	55	26
Energy consumed (kWh)	1374.1	1067.1	1018.7
Working Hours	519.4	278.0	218.0
hours of the month	720	744	672
% Use	72.1	37.4	31.3

## Reliability / Environment

Thanks to Spirale Vision, our simplified refrigeration circuits feature fewer parts prone to wear (solenoid valves): an excellent asset to ensure your equipment a longer service life.

In addition, Spirale Vision includes a preventive maintenance tool: each component is individually monitored (solenoid valves, compressors) by action or duration counters. A global summary table makes it possible the plan preventive interventions.

Finally, to prevent any malfunction of your equipment and to protect the environment, we have developed the most advanced gas leak control: you are warned of any effect on the performance of your equipment.

# EXCAL 3

“A perfectly dimensioned range”

- ▶ Extreme temperatures: from -90 °C to +250 °C or -50°C to +180°C
- ▶ Humidity tests (Humidity model): RH from 5% to 98% (for temperatures from +10 °C to +90 °C)
- ▶ An unparalleled high-performance panel: from 2 °C/min to 25 °C/min

## Aeraulics

Air circulation is optimised thanks to the double flow ventilation. This solution has a number of advantages:

- ▶ Products are temperature treated simultaneously on all sides.
- ▶ Homogeneity on load is excellent regardless of the volume of your load.

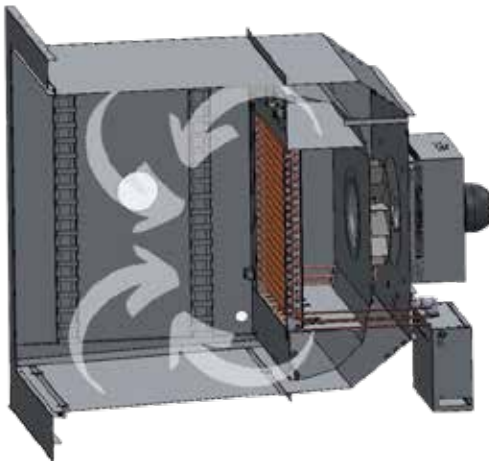

Circulated by a high-temperature fan, air is drawn in and conditioned in the technical compartment, then sent back into the entire test volume. The innovative aeraulic of the tank significantly improves the airflow speed to obtain a natural homogeneity.

## Humidity production

Climats uses moisture production by low pressure steam or «boiler» type.

This system, of total reliability, is very close to natural phenomena.

As standard, the boiler is controlled by high and low levels and a cartridge heater brings the water to a boil for the moisture production.

According to the cabinet humidity capacitive sensor, Spirale Vision software manages the boiler control and brings a Relative Humidity (RH) regulation fineness to 1/10%RH. The standard humidity range from 5 to 98% for temperatures from +10°C to +90°C, is limited by a minimum dew point of -5°C to +95°C maximum..

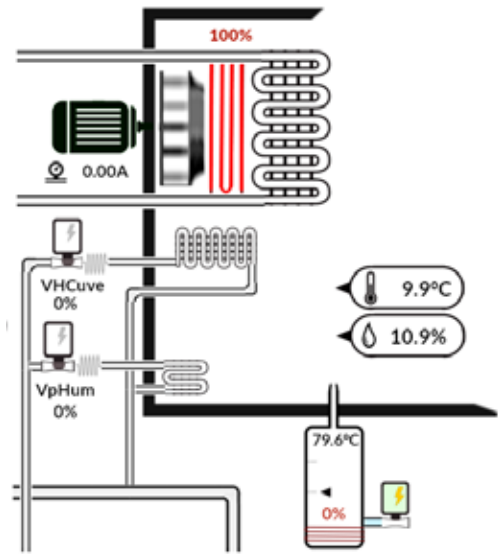

## Temperature and humidity calibration

The Spirale Vision double entry calibration table can be filled in manually or automatically using a standard communicating with Spirale Vision.

Measurement accuracy ensures a regulation stability between +/- 0.1 °C and +/- 0.3 °C.

Workspace homogeneity, according to the standard IEC EN 60068-3-5, is between +/- 0.4 °C and +/- 1.5 °C.

Hygrometry: Reliability, accuracy and regulation stability between +/- 1% and +/- 3%.

Relative humidity range between 5% and 98% and temperature range between +10 °C and +90 °C.

Nominal test conditions: Empty chamber without option. Water condensing type, clean cooling water supply at +18°C with a flow and pressure rate (3 bar mini; 6 bar max) matching the technical specifications of the chamber.

400 V three-phase 50 Hz/60 Hz mains power supply.

Maximum performance conditions maintained up to : Teau=22°C (water condensing type) / T air=25°C (air condensing type)

Useful dimensions do not include the thickness of the rack for the shelves (25 mm on each side).

\* Cabinet depth reduced by 10 mm

\*\* Cabinet depth reduced by 20 mm

Interior dimensions (mm)	Exterior dimensions (mm)	Minimum Temperature (°C)	Cooling downrate according to IEC 60068-3-5 (K/min)	Rates given from +180°C to the value indicated in this column and vice-versa	Heating up rate according to IEC 60068-3-5 (K/min)	Condenser type A (air) W (water)	Maximum power consumed (kW)	Net weight (kg)	Sound pressure level dB(A)
--------------------------	--------------------------	--------------------------	---	--	--	--	-----------------------------	-----------------	----------------------------

**EXCAL 140** 151 liters **Mobile**

EXCAL 1421-T/H	W=540 D=400 H=700	W=783 D=1634 H=1842	-70	5	-70	5	A/W	7,9	440	64
EXCAL 1451-T/H			-50	6	-40	6,2	A/W	5	421	60
EXCAL 1452-T/H*			-50	11	-40	15	A/W	8	464	61
EXCAL 1423-T/H*			-80	12	-70	15	A/W	12,6	490	65

**EXCAL 220** 227 liters **Compact**

EXCAL 2251-T/H	W=540 D=600 H=700	W=783 D=1912 H=1842	-50	5,1	-40	6	A/W	5	459	60
EXCAL 2221-T/H			-70	5	-70	5	A/W	7,9	470	64
EXCAL 2252-T/H			-50	10	-40	14	A/W	8	497	61
EXCAL 2223-T/H			-80	10	-70	14	A/W	12,6	520	65
EXCAL 2224-T/H*			-80	15	-70	15	A/W	17,1	610	66

**EXCAL 400** 400 liters **Optimum**

EXCAL 4051-T/H	W=700 D=650 H=900	W=979 D=1956 H=2064	-50	4,8	-40	10	A/W	8,5	529	60
EXCAL 4021-T/H			-70	3,5	-70	8	A/W	11,1	353	64
EXCAL 4025-T/H*			-85	15	-70	17	W	22	820	66
EXCAL 4052-T/H			-50	8	-40	10	W/A	8,7	572	61
EXCAL 4053-T/H			-50	19	-40	19	W	17,4	724	64
EXCAL 4023-T/H			-75	7	-70	8	A/W	13,4	590	65
EXCAL 4024-T/H			-80	10	-70	10	A/W	16,9	680	66

**EXCAL 540** 540 liters **Multipurpose**

EXCAL 5421-T/H	W=700 D=850 H=900	W=979 D=2156 H=2064	-65	2,5	-65	8	A/W	11,1	575	64
EXCAL 5423-T/H			-75	5	-70	8	A/W	13,4	625	65
EXCAL 5451-T/H			-50	3,8	-40	10	A/W	8,5	586	60
EXCAL 5452-T/H			-50	7	-40	10	A/W	8,7	616	61
EXCAL 5453-T/H			-50	18,5	-40	19	W	17,4	767	64
EXCAL 5424-T/H			-80	8	-70	10	A/W	16,9	715	66
EXCAL 5425-T/H			-85	15	-70	16	W	22	860	66
EXCAL 5427-T/H			-85	20	-70	15	W	24,7	890	67
EXCAL 5428-T/H			-90	25	-70	20	W	35,5	920	68

**EXCAL 770** 770 liters **High Performance**

EXCAL 7723-T/H	W=900 D=950 H=900	W=1181 D=2279 H=2064	-70	4	-70	5	A/W	13,2	705	65
EXCAL 7752-T/H			-50	6	-40	7	A/W	9,8	702	61
EXCAL 7753-T/H			-50	15	-40	16	W	18,5	848	67
EXCAL 7724-T/H			-75	7	-70	7	A/W	18,2	795	66
EXCAL 7725-T/H			-80	10	-70	13	W	23,1	940	66
EXCAL 7727-T/H			-85	14	-70	13,5	W	23,7	970	67
EXCAL 7728-T/H			-90	18	-70	18	W	33,3	1000	68

**EXCAL 1000** 1000 liters **Universal**

EXCAL 10052-T/H	W=1000 D=1000 H=1000	W=1285 D=2325 H=2165	-50	5	-40	6	A/W	9,8	875	61
EXCAL 10023-T/H			-70	2	-70	4,5	A/W	13,2	870	65
EXCAL 10024-T/H			-75	4,5	-70	6,5	A/W	18,2	960	66
EXCAL 10053-T/H			-50	11	-40	11	W	18,5	1007	65
EXCAL 10025-T/H			-75	7	-70	10,5	W	23,1	1105	66
EXCAL 10027-T/H			-85	8	-70	11	W	23,6	1135	67
EXCAL 10028-T/H			-85	12	-70	15	W	33,3	1165	68
EXCAL 10029-T/H**			-85	18	-70	20	W	44,9	1225	70

**EXCAL 1400** 1416 liters **Powerful**

EXCAL 14052-T/H	W=1150 D=1100 H=1120	W=1485 D=2250 H=2270	-50	4	-40	5	A/W	9,8	965	61
EXCAL 14053-T/H			-50	8	-40	8	W	18,5	1113	64
EXCAL 14023-T/H			-70	2	-70	3	A/W	13,2	970	65
EXCAL 14024-T/H			-75	4	-70	5	A/W	18,2	1060	66
EXCAL 14025-T/H			-75	6	-70	6	W	23,1	1205	66
EXCAL 14027-T/H			-85	7	-70	7	W	23,6	1235	67
EXCAL 14028-T/H			-85	10	-70	10	W	33,3	1265	68
EXCAL 14029-T/H			-85	12,5	-70	17	W	44,9	1285	70

**EXCAL 1800** 1932 liters **Industrial**

EXCAL 18052-T/H	W=1150 D=1500 H=1120	W=1485 D=2825 H=2270	-50	3	-40	3,6	A/W	9,8	1197	61
EXCAL 18053-T/H			-50	6	-40	6	W	18,5	1407	65
EXCAL 18023-T/H			-70	1,5	-70	1,5	A/W	13,2	1260	65
EXCAL 18024-T/H			-75	3	-7	3	A/W	18,2	1350	66
EXCAL 18025-T/H			-75	4	-70	4	W	23,1	1495	66
EXCAL 18027-T/H			-85	5	-70	5	W	23,6	1525	67
EXCAL 18028-T/H			-75	8	-70	8	W	33,3	1555	68
EXCAL 18029-T/H			-85	10	-70	10	W	49,9	1615	70

# EXCAL<sup>3</sup> OPTIONS

## To organize the structure of your chamber



- ▶ Integration of additional portholes on the sides, ceiling, door and even in the window (diameters between 80 and 200 mm).



- ▶ Integration of specific customer windows, connectors or sensors adapted to your requirements.



- ▶ Integration of notched cabinet portholes for connecting products before inserting them into the cabinet.

- ▶ Increased loading capacity for each level using reinforced shelves.
- ▶ Increased loading capacity placed on the base of the test space.
- ▶ Reversible door opening.
- ▶ Integration of inserts for precise mechanical assemblies.
- ▶ 316L stainless steel cabinet and nickel-plated evaporator to protect the test volume from chemical hazards.
- ▶ Air extractor for renewing the air inside the test volume.
- ▶ Customization of the color of your chamber.

## To develop your tests

You have a multitude of input and output units for your customized adaptations and applications.

- ▶ Temperature extension to +200°C and/or +250°C
- ▶ Camera to record shots of your product inside the tank during the tests.



- ▶ Relative humidity sensor for measuring or regulating.



- ▶ PT100 data acquisition card or thermocouple.



- ▶ Additional data acquisition units.



- ▶ Module with 6 relay outputs/ 6 logical inputs.

- ▶ Bar code reader.

- ▶ Specific operating mode development: regulation on the average of several sensors, incoming regulation information on dry contact, START & STOP for regulation and ventilation when taking measurements.

- ▶ Specific digital communication such as IEEE 488, and 0/10v analogue control.

- ▶ Remote Panel PC for controlling your peripherals remotely.

- ▶ Supports MODBUS communication protocol accessories.

# “Optimize your environmental test chamber by combining standard accessories and measuring devices”

## To make your tests safe



- ▶ Door opening safety alarm



- ▶ Door lock for customer process

- ▶ Door safety over temperature range.
- ▶ Variator to select the fan speed



- ▶ Air dryer for preventing the formation of humidity by sweeping with dry air or nitrogen.

- ▶ MINI/MAX electronic temperature safety unit on separate PT100 sensor.
- ▶ Pre-installation of an emergency stop to be interfaced with your test benches.
- ▶ Integration of dedicated thermal fuses.
- ▶ Securing of your high-power cables via the 10/16A safety socket.
- ▶ Monitoring of the condenser water flow 1.5 to 3 hp, 4 to 10 hp and 15 to 37 hp

## To improve the chamber's environment

- ▶ Installation of a demineralized water generator for long-term humidity tests.

- ▶ Installation of water filter cartridges for short-term humidity tests.

- ▶ Installation of an additional chiller to ensure cooling of the installation.



- ▶ Replacement of the water-cooling system with a remote air-cooled condenser solution.

- ▶ Integration of an audible warning device on event or alarm.

- ▶ 3-colour tower light.

- ▶ Integration of a demineralized water tank for use during humidity tests.

- ▶ Reinforced machinery soundproofing.

- ▶ Demineralizer kit to ensure the production of high-quality demineralized water

- ▶ Filtration system for boiler to limit the shattering of the boiler which could disturb its operation, or even cause its safety.

- ▶ Frost control to guard against the risks of icing on products

**Please contact us,  
we are continuously  
enhancing  
these features!**

Europe  
Asia  
America  
Africa



## An international presence

---

At the core of the Climats development strategy,  
Export relies on a wide-ranging network of intercontinental distributors.  
Our partners market and service Climats equipment all over the world;  
they are fully skilled in our technology and fully committed to a long-term relationship.



# Climats

---

Technopole Bordeaux Montesquieu - 2-4 Allée Jacques Latrille - CS 50067 - 33650 MARTILLAC - FRANCE  
Tel. +33 (0)5 56 20 25 25  
sales@climats-tec.com - www.climats-tec.com